



Search this site:



- [About](#)
- [People](#)
- [Groups](#)
- [Tools](#)
- [Collections](#)
- [Chronology](#)
- [Bibliography](#)
- [Histories](#)
- [Conference](#)
- [Preservation](#)
- [Education](#)
- [Support and Credits](#)

[Home](#) » [Design Device - A Unique Video Synthesizer](#)

## Design Device - A Unique Video Synthesizer

<b>Publication Type</b>	Unpublished
<b>Authors</b>	<a href="#">DeWitt, Tom</a>
<b>Source</b>	(1976)
<b>Keywords</b>	<a href="#">tool-text</a>
<b>Abstract</b>	<p>Proposal from WHMT TV by Tom De Witt to the New York State Council on the Arts. It contains descriptions of how specific synthesizers work. When it was supported at \$10K rather than the requested \$22K, Electronic Body Arts redesigned the project and ended up with Pantomation. The Design Device was an invention of Tom DeWitt and Phil Edelstein. DeWitt in a letter to Woody and Steina Vasulka dated this document 1976.</p>

[Full Text:](#)

Proposal from WMHT TV to  
The New York State Council on the Arts  
for  
A Unique Video Sythesizer

### Historical Background

In 1975, Tom DeWitt and Phil Edelstein spent a weekend in Poughkeepsie visiting with Tom's family. Retreating to the attic rooms, they sketched out a proposal for a video synthesizer. The setting must have been influenced to some extent by Tom's father, David DeWitt, an IBM Fellow whose lifetime of contribution to electrical and electronic engineering including basic work in radio, television, radar, computers, transisors and semi-conductors. His 40 foot ham antenna mast was visible from the room in which Tom and Phil feverishly sketched their synthesizer, and Tom decided that calling their instrument the Design Device would bless the proiect with his father's initials.

Returning to Albany, Tom put words to the sketches and dragged in documentation that had accumulated during his NEA Fellowship in Video over the course of a year. With graphic design help from his partner in art, Vibeke Sorensen, the sketches began to look legible to the eye of electronics engineers. Using the Electronic Music Studio at the University at Albany as a base, Tom and Phil phoned around the country to get price fixes for parts and interviewed potential allies in the proposed construction. The package was given a final draft and a pack of copies were sent to the New York State Council on the Arts under the aegis of the Capital District's PBS station, WMHT with the expectation of starting in Albany the kind of facility in which Tom and Phil had both participated in New York City, WNET's Television Laboratory.

There was a grant, but at half the proposed budget, the Design Device proved out of reach, and Pantomation was the born as a lower cost alternative.

Tom Ditto

August 2000

This proposal describes a new kind of video synthesizer which uses the graphic potential of the video medium for a programming language. The instrument, called the Design Device, will perform video synthesis and signal processing under control from a mini computer which reads a specially formatted picture language. This programming language will permit artists to prepare ideas away from the studio and provide a permanent record on paper of all useful programs.

Review of Existing Video Synthesizers and Ideas for a New One

To free the video artist from the confines of the real camera-recorded world, it is necessary to develop instruments which generate a television compatible signal from raw electronics. A synthesizer is the paint and palette of the video artist, a device which lets the artist construct spaces from the dictates of imagination.

The first video synthesizers began to appear almost a decade after the development of complete audio synthesis systems. There are compelling reasons for this delay. The development of a time variant artform is just now being born in the visual arts, centuries after the establishment of a related set of time variant structures in music. Technically, the video synthesizer is more complex than its audio cousin. Video signals cover a frequency spectrum 100 times greater than audio and must be constructed according to a precise timing synchronization which does not exist in the one dimensional audio signal. Consequently, design concepts and instrument components are now coming together for the first time.

There have been two approaches to video synthesizer design, vector graphics and signal intensity. This split is a consequence of the television system itself which uses a one dimensional high frequency signal to describe a two dimensional field of much lower frequency. The systems developed by Steve Rutt and Bill Etra, Computer Image Corp.,

Vector General, and others operate on the x and y deflection amplifiers of a cathode ray disolav. The synthesized or processed images coming from these devices are rescanned by

Design Device - A Unique Video Synthesizer | Video History Project - Experimental Television Center

display. The synthesized or processed images coming from these devices are recorded by a conventional camera for recording on video tape. Digital signal synthesizers, on the other hand, such as those developed by Steven Beck, Dan Sandin, and EMS Ltd., operate on the intensity or-"z" component of the video signal. Their output is made compatible with video standards by processing in a color encoder. The two approaches can be combined in a single device. In fact, Sandin has worked extensively with a computer controlled vector display, and RuttEtra synthesizers are invariably teamed with keyers, colorizers and other signal processors. However, no one has come out with an integrated package that incorporates both approaches. The Design Device will attempt this marriage of design principles.

All the artist designed synthesizers are "modular", that is, specialized devices are linked by patch cords which are manually inserted to complete a complex program. Modular design is essential in video, because it permits parallel and simultaneous processing of high frequency signals. The chief drawback of the general purpose computer in video synthesis is that it performs one operation at a time and cannot keep up with the video clock. As in the development of the audio synthesizer, artists have provided engineers with functional module building blocks which efficiently accomplish commonly needed functions. Modular design also permits a wide range of interconnections depending on the "patch" made between them. For example, a system of only 8 modules, each with a single input and a single output can be patched in over 40,000 different ways.

While modular systems provide both variety and efficiency, they also can present the artist with a confusing welter of two ended wires which makes live performance difficult and leaves him with no permanent record of his patch. The first step in improving this situation came with the introduction of the matrix switching systems of the Arp and EMS synthesizers, adapted for video by Woody and Steina Vasulka. These systems have manually set crosspoints and permit patchfields to be recorded by graphic notation. Going a step further Don Buchla and Bell Labs have developed computer controlled patchfields which are notated with a verbal language. The Design Device will have an electronic switch system, but rather than a verbal language, it will be controlled by a graphic notational system.

All existing video and audio synthesis systems use a building block called the oscillator. The most common technique for generating forms is called additive synthesis in which the output waveforms of oscillators are mixed to form a waveform, which is the sum of their combined outputs. It is theoretically possible to duplicate any natural waveform by summing many sine waves of different frequency. This approach has led to the construction of synthesis systems with dozens of oscillators. When such systems became untenable because of the large number of signal paths, a device was introduced by Don Buchla which generated a waveform from discretely set increments. This device is now known as a sequencer. It can be used as an oscillator or a controller in voltage controlled systems. Information is loaded into a sequencer manually by setting dozens of potentiometers. Like the patch cord system, it must be set up from scratch every time it is used. There is no convenient way to notate for this device. The general purpose computer can be used as a kind of sequencer since its memory stores lists of numbers, but again the problem of cycle time limits its use to low frequencies. Recent innovations in

semiconductor technology, however, have put digital memory within the reach of the video synthesizer. Using modular design techniques, it is possible to build an oscillator module

synthesizer. Using modular design techniques, it is possible to build an oscillator module with a programmable output. In the Design Device there will be two such oscillators. The stored waveform will be loaded from a sampled graph drawn by the artist and scanned by a conventional television camera.

Given that this small memory can serve to store waveforms, a method must be found to clock out its stored information. oscillators such as those found on the RuttEtra or Steven Beck's synthesizer must be synchronized to the rest of the synthesizer in order to produce stable patterns. While it is relatively easy to make a voltage controlled oscillator, it is difficult to maintain synchronization for an analog module. The Design Device uses the video sync generator itself as the clock for its memories. The rate at which the memories are read out is determined by a simple binary counter which is preset to the number of subdivisions it makes of the sync signals. Hence all the patterns produced by the memories are stable both with respect to the video signal and to each other.

The contribution of commercial manufacturers of television equipment must not be overlooked in describing the development of video synthesis. Every news broadcast these days uses chroma key backgrounds, and this technique can prove very handy for the artist. The trouble is that most synthesizers operated on black and white inputs which are synthetically colorized, and the standard chroma keyer must have separate red, green and blue inputs in order to work. The Design Device will have an encoded chroma keyer which will derive the RGB signals from a color tape input, so it will be possible to build generations of imagery by operating on sections of the image encoded in a particular color. This may sound like a major electronic undertaking, but the commercial manufacturers of television sets have put the chroma decoding circuits on three relatively simple integrated circuits. Building an encoded chroma keyer is simply a matter of opening up a color television and using its decoder circuitry. Paik and Abe performed this operation on a Trinitron at the WNET TV Lab. Unfortunately they did not realize this application of their modification.

Another area in which broadcast television people have made great strides is in time base correction. For the mere sum of \$12,000 the broadcaster can replace his \$100,000 quad vtr with a time base corrector and a Sony video cassette. This means that an inexpensive vtr can be used as a source in a switcher. For an artist making a multi generational tape, such time base correction is essential. For an artist working on a shoe string budget, \$12,000 for a time base corrector is out of the question. The Design Device will have two kinds of "pseudo" time base correction. It has a rescan system which will re enter a black and white image from an external tape source and even permit the luxury of relocating the input image into a new space in the frame. It will also use the cheap part of the big commercial time base correctors which is a digital memory system, only the Design Device will only have one bit of time base correction. This will eliminate the

expensive D to A and A to D converters and the eight bit wide memory system. The input through this cheap time base corrector will be a simple black or white pulse train which happens to be perfect for triggering a keying circuit.

The most common "special effect" available on commercial switchers is the geometric pattern called the wipe. The technique for generating wipes is quite straight forward and is

pattern called the wipe. The technique for generating wipes is quite straightforward and is used by Beck and others in artist oriented synthesizers. The pattern of the wipe is formed by the waveshape of an oscillator, and such wipes as diamonds, ellipsoids, and boxes are easily formed with an analog oscillator. The memory oscillator of the Design Device will permit virtually any shape of wipe to be made, and there will be provision for making multiples of any shape.

One of Steve Beck's contributions to video synthesis was a perceptive analysis of spatial composition. By dividing the image into components of point, line and volume he was able to design modules to achieve each objective. Among his inventions were devices that took complex images and reduced them to these spatial elements. In many ways, this paring down of images is important because it allows the artist to simplify complex spaces and combine them inside a single frame. The Design Device will contain an outline generator which will reduce volumes to lines. This will permit many shapes to be seen through each other. Unlike Beck's outline generator, however, the Design Device will be able to fill in horizontal lines. This technique was perfected by a commercial switcher manufacturer, Grass Valley Group, and involves an extra processing step which is very similar to the one bit time base correction.

The unique advantage of vector graphic systems like the RuttEtra synthesizer is its ability to reposition an image after it is recorded. Among the manipulations possible on such a system are electronic zooming, left-right inversion, top-bottom inversion and rotation. The Design Device will have processing modules which will permit all of the above effects. The rotation function is not normally available with commercially sold RuttEtra systems because it requires a low frequency sine-cosine generator. This pair of precisely timed control voltages will be available in the Design Device through its memory oscillators,.

At the beginning of this discussion of video synthesizers, I called such devices the artist's paint and palette, and no module better fits this description than the colorizer. There are many designs for colorization devices both commercial and unique. In systems which use a camera encoder to generate the final output, the colors are determined by mixing red green and blue components. While pleasantly reminiscent of mixing colored paint, this system is less efficient to use than the colorization made possible by video color parameters: luminance, chrominance and hue. With the latter system it is possible to pass a previously encoded color signal through the synthesizer and recover it unchanged at the other end (through the luminance channel). Now colors can be added by entering signals into the hue and chrominance channels. Where grey scale encoding is used such as in quantization, the single hue parameter can produce rainbow-like effects. The Siegel colorizer uses grey scale encoding to modulate all three parameters simultaneously. Dividing the inputs into three channels gives an increased degree of control over the final output. The Grass Valley colorizer uses the luminance, chrominance, and hue parameters but is not voltage controlled and hence is not dynamic. The Design Device will have a colorizer-sync adder which vary color through four complete rotations of the primaries and their mixes, permitting voltage controlled hue and saturation, and pass a signal unchanged through the luminance port with manually adjustable controls for pedestal and gain.

#### A Graphic Guitar

The Design Device will be a self contained video synthesizer which can originate graphic patterns and can process prerecorded video signals. It will have provision for interfacing

External video sources such as video tape recorders and cameras will be entered into the Design Device through an Input Module (figure 1). There will be four specialized input ports. All inputs will be clamped and sync separated.

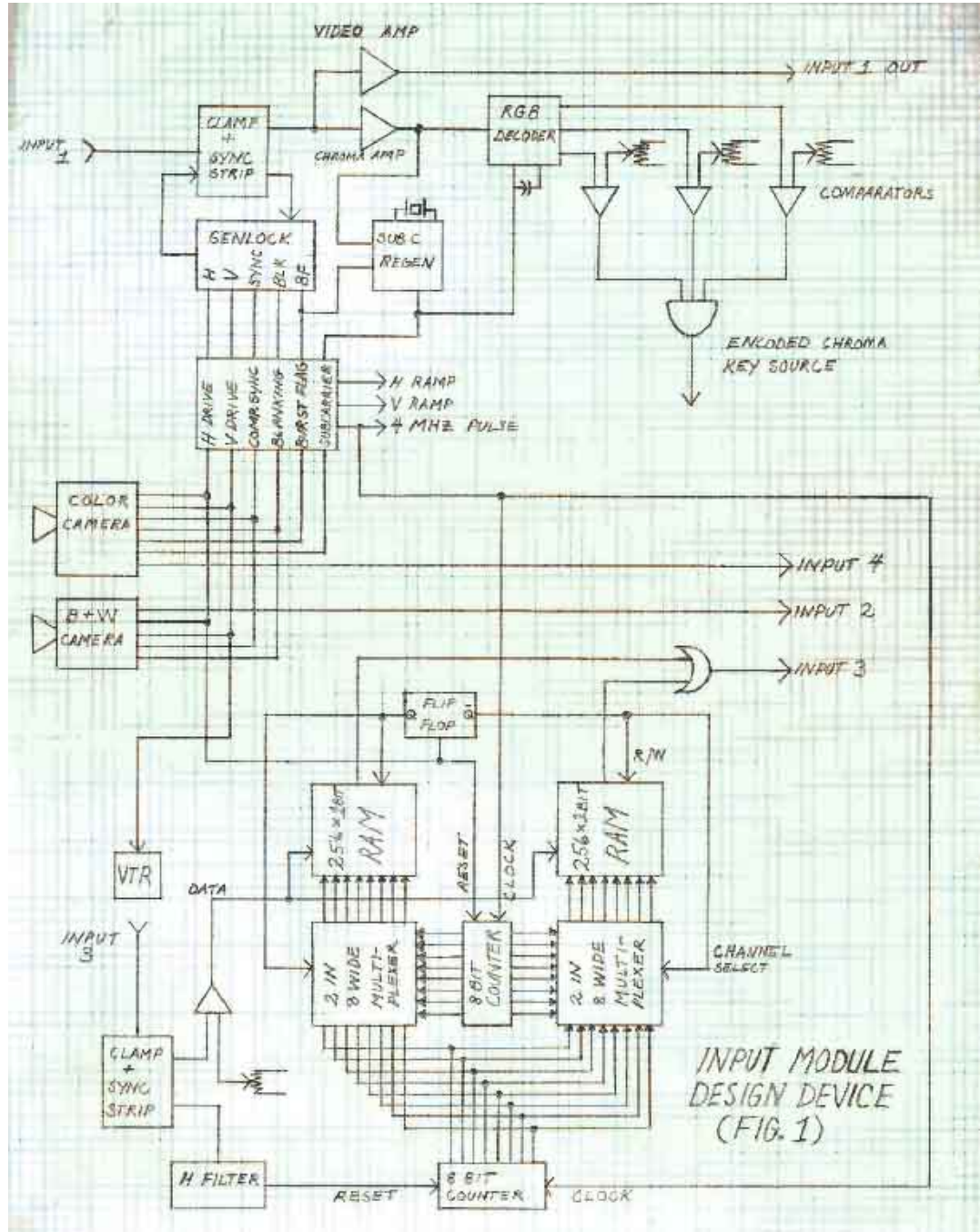

Input One is intended for a color signal. The Input Module will clamp the signal and strip sync. Timing signals extracted from the Input One signal will be H drive, V drive, blanking, composite sync, subcarrier and burst flag. These signals will be connected to the Sync Generator for gen lock. There will be a manual adjustment for the phase of the subcarrier. The video portion of the Input One signal will be amplified and distributed to the Input One terminal of the analog matrix described later. There will be a manual adjustment for the chrominance of the distributed signal. The video portion of the Input One signal and all

the enhancement of the distributed signal. The video portion of the input one signal and all the other external video signals will be distributed through the Design Device as non-composite 0 to + 2 Volts.

Hardwired to Input One will be a Chroma Decoder system nearly identical to ones used on "solid state" television receivers. The RGB outputs of the decoder will be analyzed by comparators with manually adjusted thresholds, and the consequent logic pulse will be distributed into the Design Device matrix.

Input Two is for a black and white camera which is used to rescan a RuttEtra Display. The camera will receive its sync from the Design Device sync generator. Input Three is for any vertical lock vtr. This signal is processed through an analog comparator and is then loaded into a one bit time base corrector. The time base of input Three is matched to Input One within a window of one line and will have horizontal resolution of 256 points. Input Four accepts an external video camera, either black and white or encoded color, which is synched from the Design Device Sync Generator.

The Input Module will drive a video Sync Generator which will synthesize all timing signals not derived from Input One. In the case of a black and white signal, the Sync Generator will provide a free running 3.58 MHz subcarrier and a horizontal drive triggered color burst flag which can be used to synthesize color. In the case of an EIAJ heterodyned color signal, the subcarrier will be derived from the incoming signal. In these cases, the output of the Design Device will not be directly broadcast compatible, but it may be made so by subsequent time base correction. The Sync Generator will also provide a 4.09084 MHz clock pulse ( 260 x H) phase locked to the subcarrier and 15,750 and 60 Hz sawteeth triggered by the horizontal and vertical drives.

The signal processing modules of the Design Device will consist of individually addressable voltage controlled and digital devices with compatible inputs and outputs. Control voltages will have a  $\pm 5$  volt range.

The primary oscillator of the Design Device will be an 256 x 8 bit random access memory (RAM) with an 8 bit digital to analog converter (DAC) as an output buffer. The contents of the memory

will be loaded from a Camera Controller. Waveforms to be loaded into the RAM will be prepared on specially formatted graph paper marked in a rectilinear grid of 256 x 256 lines. The two RAM modules on the Design Device will share one Camera Controller. A switch on the Controller will select which memory is being loaded.

The RAM modules will be read out by a Programmable 8 Bit Counter. The Counter can be advanced by inputting an external trigger. This trigger is subdivided by a number derived from a voltage controlled counter system which essentially is an inexpensive digital to analog converter. Normally the Programmable counter runs from 0 to 255 and then recycles, but provision is made of computer addressing to preset and reset the counter. When implemented subsections of the RAM can be read out selectively.



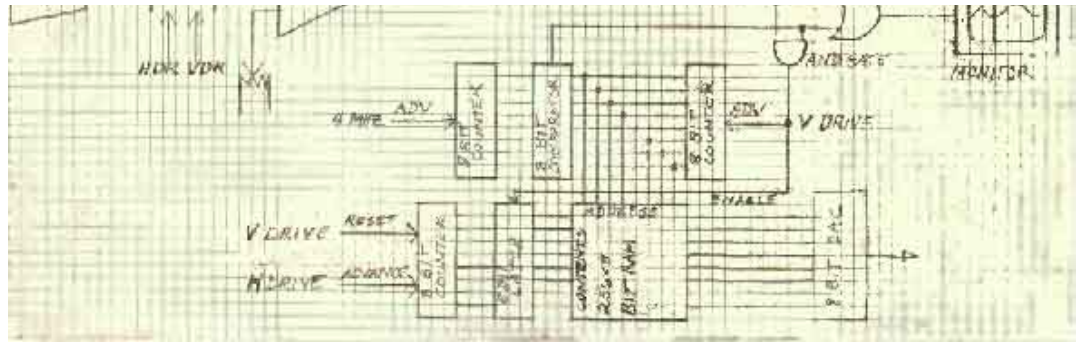

### 8 Bit Programmable Counter Architecture

The Wipe Generator will be built around a triangle wave oscillator which can be varied in frequency and phase from one to ten

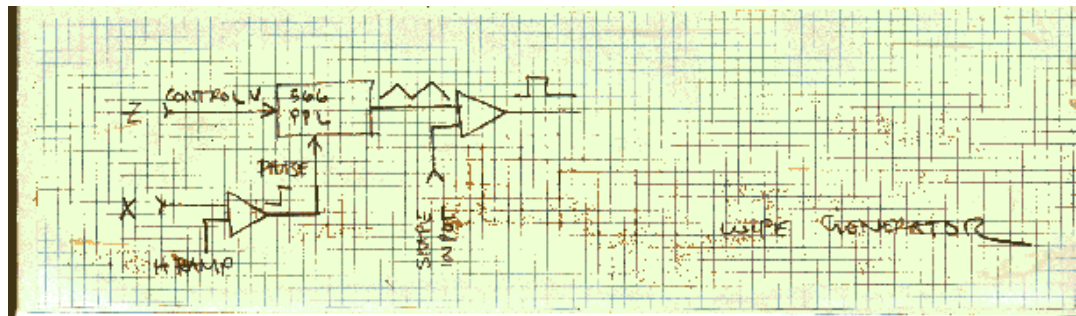
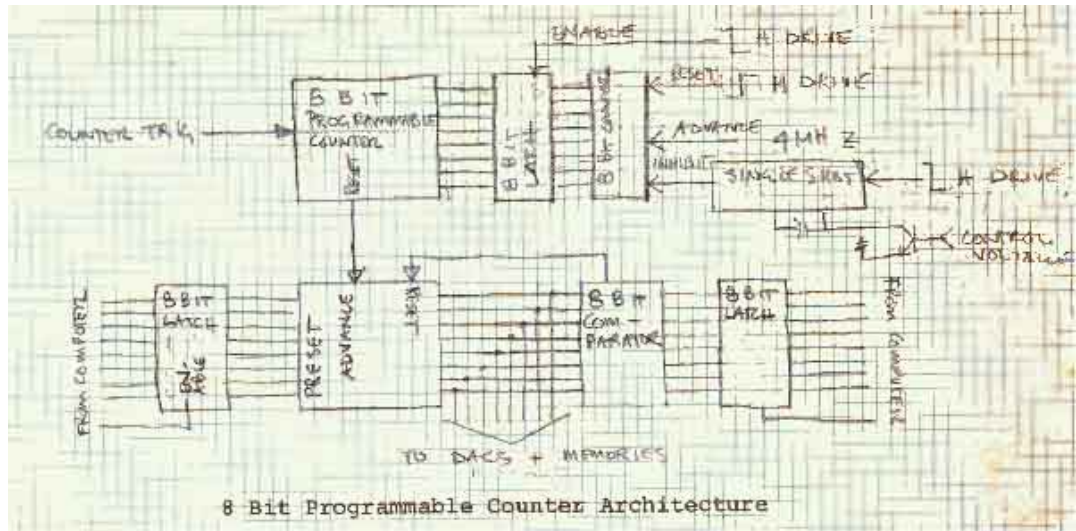

times horizontal frequency. The output of the triangle oscillator will be compared with an external input to produce the wipe pattern. The X input will permit the wipe to moved from left to right. The Z input will multiply the number of wipe patterns from one to ten by

increasing the frequency of the triangle oscillator. Size of the wipe will be determined by biasing the Wipe Generator Shape input.om one to ten times horizontal frequency. The

Design Device - A Unique Video Synthesizer | Video History Project - Experimental Television Center

Using the Wipe Generator Shape Input, one to ten times horizontal frequency. The output of the triangle oscillator will be compared with an external input to produce the wipe pattern. The X input will permit the wipe to moved from left to right. The Z input will multiply the number of wipe patterns from one to ten by increasing the frequency of the triangle oscillator. Size of the wipe will be determined by biasing the Wipe Generator Shape input.

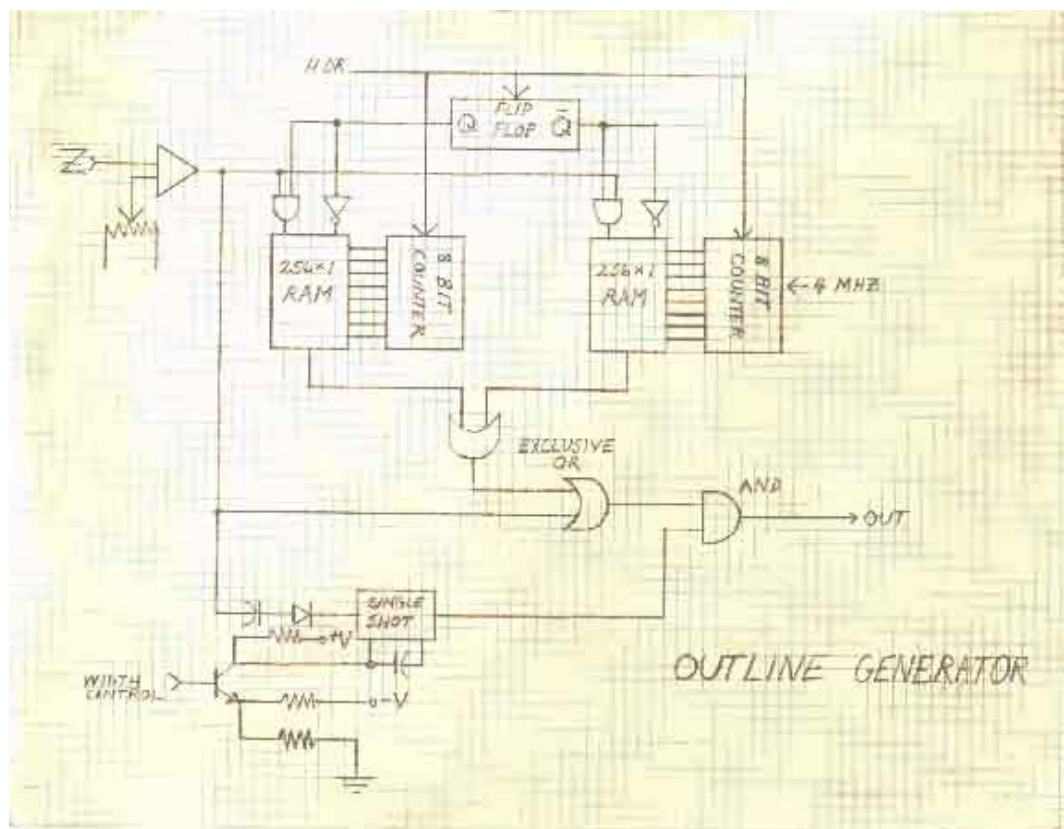

The Outline Generator will consist of an edge triggered single shot with variable pulse width. This single shot will be fired on two conditions: 1) when there is a level change on a comparator looking at the video input; 2) when there is a level change on a comparator looking at the difference between the incoming signal and a one line delay of the incoming signal. The delay line to be used is identical to that used in the one bit time base corrector.

The four Multipliers on the Design Device are four quadrant multipliers developed for modular synthesizer use by Steve Rutt. The voltage of their outputs is equal to the product of their two inputs. Hence they can be used for amplitude modulation, polarity inversion, and frequency doubling.

The RuttEtra Display system to be used on the first Design Device is a Model 4A Display built in 1974. The rescan camera will be a studio G.E. vidicon being donated by WMHT from surplus stock. The Display will have two buffer amplifiers with manual bias control and an intensity compensated video amplifier.

The two keyer circuits on the Design Device are based on identical circuits. The major difference between them is that Keyer One will use a single signal as both a key and video

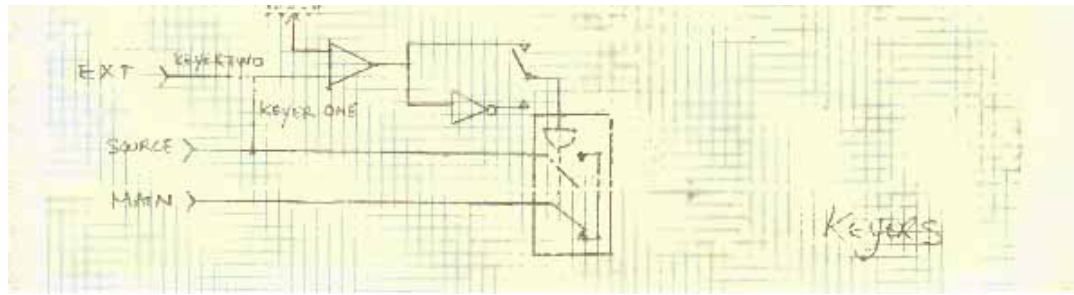

The inverter circuit consists of a high speed op amp and is intended for reversing polarity of a video signal while maintaining its black level clamp.

The Voltage Controlled Mixer is based on the MC 1445 integrated circuit. It can be used as a two quadrant multiplier, a video mixer, a keyer, a transparent keyer, a pulse width modulator and a voltage controlled amplifier. Detailed construction designs

for this circuit have been made public by Dan Sandin. The 1445 has also been used by Steve Rutt and Carl Geiger in their synthesizer designs.

All video and analog control signals are interconnected in the Design Device through an electronically switched 32 line signal bus. The output of each module can be delegated to four of 32 bus lines. The inputs to each module can be selected from any one of the 32 lines. A block of eight lines is automatically clamped for video. The remaining 24 lines are fed through amplifiers with manual adjustments for bias and gain. outputs can be additively mixed onto a single line without distortion. Any one input line can be shared by all device inputs, but a device can select only one line per input. A section of the signal bus is shown in figure 2.

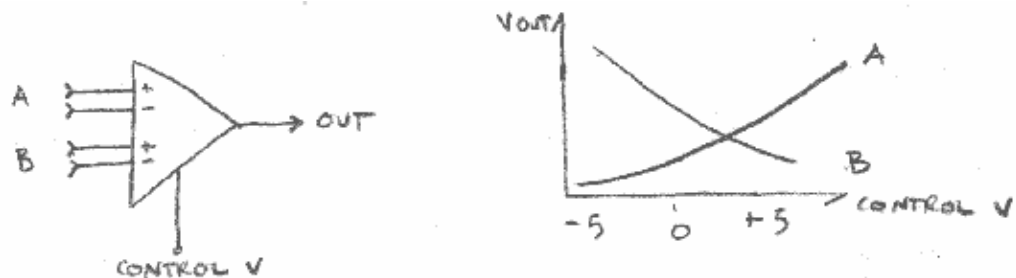

The switching system is notated graphically, and programs are written by placing marks at the cross points to be closed. The graph, 11" is mounted in front of two 32 x 32 CCD cameras, one for the Output selection and one for the Input selection. Exact registration of the program graphic is determined by use of an alignment oscilloscope shared by the two cameras and driven by their onboard DACs. The outputs from the cameras are distributed along the Design Device backplane. Six lines are distributed in an end to end bus and 160 lines ( 32 for the Input multiplexers and 128 for the Output multiplexers) are individually connected from decoders to discrete 8 wide fet multiplexed switches. The address bus and the decoders can be adapted to be operated by computer to take advantage of computer mass storage, precision timing and algorithm programming. While under direct CCD camera control, switching will take 1/30 of a second and will cause one to two bad video frames. Attached are specifications for the CCD camera to be used. Figure three is a block diagram of the Input line selection system.

The matrix graph appears on the following page  
It would be the "fretboard" of the Graphic Guitar  
The frets are read graphically by use of a solid state  
sensor, The CROMEMCO Image Sensing Module.

OUTPUTS	1	2	3	4	5	6	7	8	9	10	11	12	13	14	15	16	17	18	19	20	21	22	23	24	25	26	27	28	29	30	31	32		
Memory One																																		
Memory Two																																		
Counter One																																		
Counter Two																																		
Wave Generator																																		
Encoded Chroma Keyer																																		
Outliner																																		
Multisync 1																																		
Multisync 2																																		
Multiplic 1																																		
Multiplic 2																																		
B Drive																																		
V Drive																																		
4 Min Pulse																																		
H Ramp																																		
V Ramp																																		
Power One																																		
Power Two																																		
W Ramp One																																		
W Ramp Two																																		
Input 1 (Color)																																		
Input 2 (Black/White)																																		
Input 3 (One Bit 200)																																		
Input 4 (Camera)																																		
Joystick One - X																																		
Joystick One - Y																																		
Joystick Two - X																																		
Joystick Two - Y																																		
Inverter																																		
Internal Decoder																																		

INPUTS	1	2	3	4	5	6	7	8	9	10	11	12	13	14	15	16	17	18	19	20	21	22	23	24	25	26	27	28	29	30	31	32		
Inverter																																		



SE-1024

# CROMEMCO

IMAGE SENSING MODULE

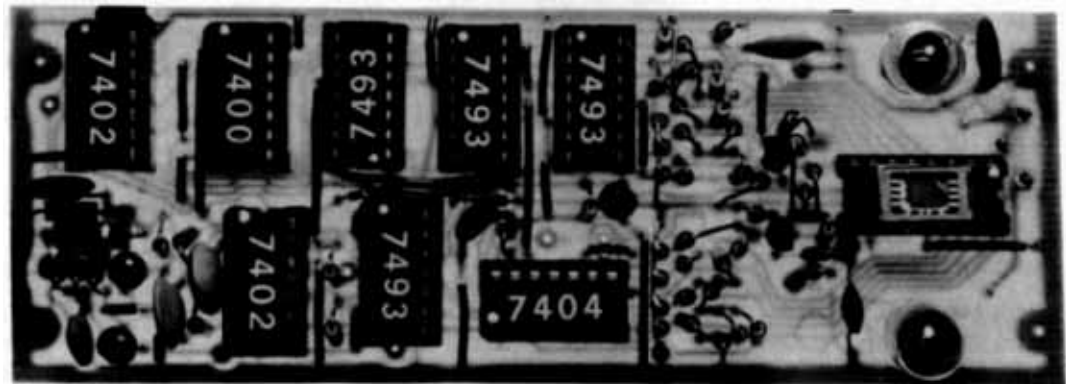

<p><b>GENERAL DESCRIPTION</b>          The SE-1024 image sensing module contains a 1024-element image sensor (Cromemco model C-1024) and all support circuitry on a</p>	<p><b>APPLICATIONS INCLUDE:</b>          -Solid state TV camera.          -Security systems.          -Automated control systems.</p>
---	---

single, compact printed circuit board. Outputs are provided to permit the direct display of a 32-by-32 element picture on the screen of an oscilloscope. The module operates at a nominal frame rate of 30 frames per second. Grey-scale information and position information are digitally encoded for complete compatibility with digital processing systems.

The module is available either as a wired and tested unit (SE-1024W) or as a kit (SE-1024K).

-Pattern recognition systems.

POWER REQUIREMENTS:

+8 volts at 300 mA.

-17 volts at 70 mA.

AVAILABILITY:

In stock now.

Model SE-1024W Wired Image Sensing Module

.....\$150.

Model SE-1024K Image sensing Module Kit

.....\$90.

Send all orders to: CROMEMCO

26655 Laurel

Los Altos, California 94022

Phone (415) 941-2967

The CROMEMCO SE-1024 image sensing module provides outputs which may be used to display a picture directly on the screen of an oscilloscope. Point H is connected to the horizontal input, V to the vertical input, and Z to the

### SCHEMATIC DIAGRAM

Z-axis input of the oscilloscope



Connections may be made to points T, E, C, and R to interface the module with other digital systems. Point T provides a TTL-level video output signal. A signal to point E may be used to disable the internal oscillator so that an external clock can be connected to point C. A signal to point R

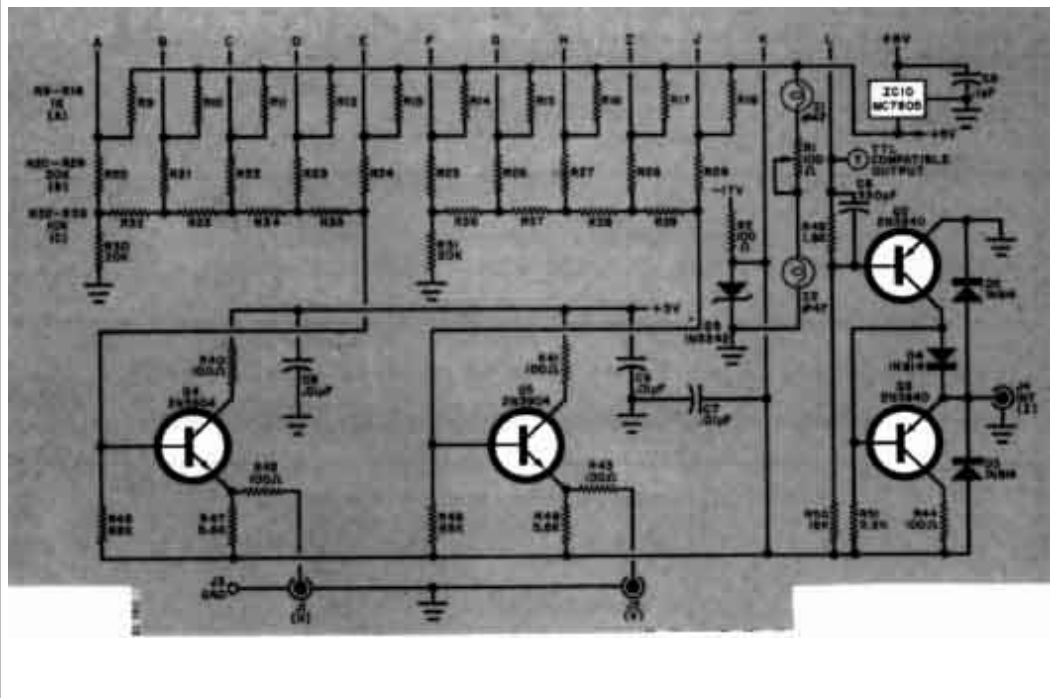
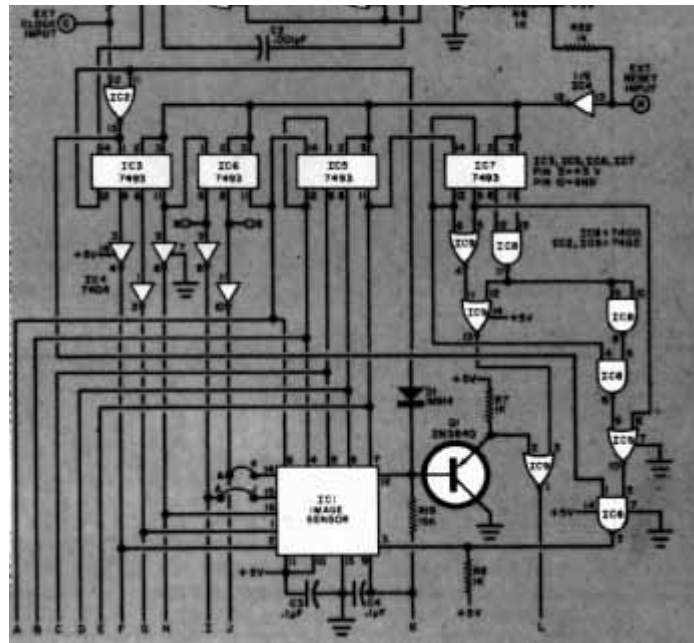

The Design Device Colorizer-Sync Adder will have input channels for the chrominance, luminance and hue parameters. The Hue will be voltage controlled through a 1440 phase shift and will make a complete 360 rotation for every two volts applied to the input. Rotation will be based on an eight channel comparator system, an idea suggested by Don Buchla. A block diagram of the hue Phase shifter is shown in figure 4. Chrominance is the control voltage for the amplification of the Hue channel. Luminance will be added to the output of the chrominance amplifier. If an incoming signal already contains a subcarrier, its phase and amplitude can be adjusted at Input One, so that the Colorizer can pass a

color signal without distortion. The Colorizer-Sync Adder will also serve as a Proc Amp. Pedestal. Gain. Sync Level and Burst Amplitude will have manual controls.

## Feasibility

Designing the Design Device is the project of Tom DeWitt under a grant from the National Endowment for the Arts. This \$10,000 grant issued in April 1975 will cover his living expenses; it is not intended to purchase components or pay for the services of engineering specialists whose participation is certainly required if the project is to produce more than a heuristic block diagram of the proposed instrument.

The concepts behind the Design Device have received encouraging responses from video artists and engineers. Among those who have expressed a desire to work on the project are Phil Edelstein, an expert in small computer systems and artist-in-residence at WNET's TV Lab; Steve Rutt, designer of the RuttEtra synthesizer and operator of Rutt Electrophysics in New York City; George Kindler, an RPI trained electronics engineer with wide design and construction experience who is also co director of the Electronic Body Arts dance group in Albany; and Roger Kent, a well versed sculptor, calligrapher, graphic designer who has just completed layout work and construction of two large Buchla 500 synthesizers. Moral and some technical support has come from Carl Geiger, Robert Moog and Don Buchla.

Test equipment and working facilities for building the Design Device are located in the Albany area at WMHT TV and the Electronic Music Studio of SUNYA. WMHT, which is sponsoring this grant proposal, is a complete broadcast television station with a color video cassette system recently installed by NYSCA for use by video artists. The Electronic Music Studio at SUNYA under the direction of composer Joel Chadabe has been a focal point for the development of new synthesis systems. Its test equipment includes a Tektronics 465 video oscilloscope, two bench waveform generators, a digital VOM, a high sensitivity analog VOM and several bench power supplies. It also houses the unique Moog CEMS audio synthesizer and an interfaced PDP 11/10 minicomputer with a user adaptable backplate. WMHT has an identical PDP 11/10. Additional test equipment available to the project includes a Hewlett Packard sampling oscilloscope which is used in debugging high speed digital circuits.

In an instrument like the Design Device many of the components are inexpensive integrated circuits which are commonly available from a variety of distributors including surplus houses. The greatest expense is putting the circuits together. This may involve tens of thousands of interconnecting wires. To simplify construction, the Design Device will use printed circuit technology to mass produce all redundant circuits. While saving enormously in labor, this technique will raise the hardware cost. This cost is seen most in the matrix switching system which forms the backbone of the synthesizer. It will be constructed of two large glass-epoxy printed circuits carrying 92 bus lines. The decoding and switching circuits will also be built on printed circuit boards which will then be mounted on generalized wire wrap boards. There will be twelve general purpose boards used in the device. Each one will have a hand constructed circuit on it containing one to three of the

processing modules. All the active circuits will be mounted in a standard 19" rack, and manual controls will be brought out on an independent control board.

In budgeting labor for construction, a general rule of \$6 per hour has been used, although the actual amount will range from \$10 to \$4 depending on the skills of the worker. As Tom DeWitt will be living on the stipend from NEA, his labor is donated. Additional savings will be realized in donated equipment from WMHT including two quality vidicon cameras, two black and white monitors, and access to the PDP 11/10. The Rutt display system to be used will be donated by Tom DeWitt at about half its market price.

In the event that the entire project is not funded, specific modules can be realized separately, but the hardware expenses worked into the matrix switch budget must be included, that is, circuit boards, power supplies and mounting gear. These would roughly double the cost of any one module as currently budgeted.

Camera-controlled Matrix Switch and Design Device Backplane		
Quantity	Part	
256	8 in, 1 out Multiplexed FET switch @ \$1.60	\$409.60
96	Dual 4 Bit Latch @ \$6.05	\$580.80
80	Dual 4 to 1 Decoders @ 3.05	\$244.00
4	16 to 1 Decoders @ 6.05	\$24.20
160	LM 318 Op Amps @ 2.50	\$400.00
2	32x32 CCD Cameras @ 200	\$400.00
10	PC Wirewrap module boards* @ 160	\$1,600.00
1	Backplane PC board	\$400.00
1	Power Supply + 15, + 5 V, 15 A	\$350.00
1	Sliding Rack Mount	\$100.00
	Passive components	\$500.00
		\$5,008.60

These are the module boards  
for all subsystems other than  
the Ram Camera Controller

Camera Controller, 2 RAMs, and 2 Programmable Counters

3 LM 319 Dual Comparators @3.00	\$9.00
4 8 Bit DACs @ 40.00	\$160.00
4 256 x 4 Bit Rams @ 50.00	\$200.00
16 4 Bit Programmable Counters @ 4.00	\$64.00
12 Dual 4 Bit Latches @6.05	\$72.60
2 Monostables @ 2.00	\$4.00
4 4 Bit Counters	\$4.00
Passive Components	\$100.00
1 Camera Controller PC Board	\$160.00
	\$773.60
Input Module	
8 LM 318 Op Amps @ 2.50	\$20.00
3 LM 319 Comparators @ 3.00	\$9.00

1	Sync Chip	\$20.00
1	Chroma Processor Combination	\$10.00
3	733 Video,Amp @ 2.30	\$6.90
2	256 x 1 Bit RAMs @ 28.00	\$56.00
10	Logic Gates @ 1.00	\$10.00
3	562 Phase Lock Loops @5.00	\$15.00
	Passive Components	\$75.00
		\$221.90
	Rutt Display and Related Circuits	
1	Model 4A Display	\$2,400.00
2	Biasing Amplifiers @150.00	\$300.00
4	Multipliers @ 150.00	\$600.00
		\$3,300.00
	Two Keyers, One Voltage Controlled Mixer, One Outline Generator, One Wipe Generator, and One Video Invertor	
16	LM 318 Op Amps @ 2.50	\$40.00
5	LM 319 Comparators @ 3.00	\$15.00

2 DPST FET Switches @1.75	\$3.50
1 MC 1445	\$7.00
2 256 x 1 RAMs @ 28.100	\$56.00
8 4 Bit Counters @ 2.00	\$16.00
Passive components	\$75.00
	\$212.50
Output	
Buchla Colorizer	\$500.00
Sync Adder and Distribution Amp	\$500.00
Trinitron Monitor	\$500.00
	\$1,500.00
Technician @ \$ 6.00/hr for 40 weeks	\$9,600.00
	\$20,636.60
Administrative Fee	\$2,063.66
	\$22,000.26

